



NORWEST

MANUFACTURING

71 SOUTH 215 WEST-RUPERT, ID- PHONE: (208) 436-1770 - FAX: (208) 436-1776

SECTION 40 ROLLED EYE FLAILS & FLAIL KNIVES



CENTER HANG FLAILS



STRAIGHT HANG FLAILS



TWISTED FLAILS



COMPOST FLAILS



ONION KNIVES &
ONION TILLER BLADES



PASTURE GROOVING
BLADES

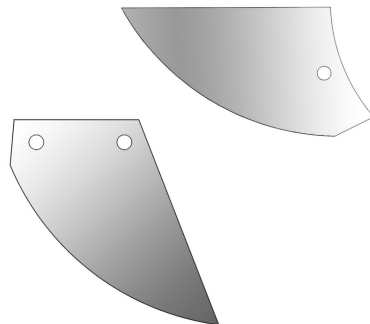

FEED WAGON
REPLACEMENT BLADES



FLAIL & CUP KNIVES



KNIFE MOUNTING
HARDWARE

CENTER HANG STEEL FLAIL

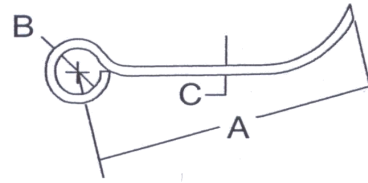

PART #	LENGTH (A)	EYE (B)	MATERIAL (C)	WEIGHT (LBS.)	OEM & PART # (REF. ONLY)
195703 (250 Pc. Min)	5-1/2"	1-1/32"	7/16"	2.16	VERMEER #510528682
195755 (250 Pc. Min)	5-1/2"	1.03"	7/16"	2.98	
195755.500 (250 Pc. Min)	5-1/2"	1.03"	1/2"	3.12	
195704 (250 Pc. Min)	6-1/4"	1-5/16"	7/16"	2.50	RENN MILL #2006-002
195194*	6"	1-1/4"	5/16"	1.83	
195135	6"	1-5/16"	5/16"	1.85	LOFTNESS
195394	6-1/2"	1-1/4"	5/16"	1.9	FALCAN
195800 (250 Pc. Min)	6-9/16"	1-1/4"	5/8"	3.64	Tapered Flail # BS2000060A-2
1958001 (250 Pc. Min)	6-9/16"	1-1/4"	5/8"	3.64	# BS200060A
195207*	7"	1-1/4"	5/16"	2.08	ALLOWAY
195068*	8"	1-1/4"	1/4"	1.7	PARMA 990603 OR HAYBUSTER BEETEC
195070*	8"	1-1/4"	5/16"	2.19	HAYBUSTER 52-09
195075	8"	3/4"	5/16"	2.11	
195412*	8"	1-1/4"	7/16"	2.96	HAYBUSTER
195060*	8"	1-5/16"	5/16"	2.24	HESSTON 7751472 or LOFTNESS or AGCO
1958002 (250 Pc. Min)	8"	1-1/4"	5/8"	4.27	
195419	10"	1-1/4"	5/16"	2.5	
195161	10"	1-5/16"	5/16"	2.55	LOFTNESS
195162*	11"	1-1/4"	5/16"	2.73	PARMA
195700	6.563	1-1/4"	5/16"	2.85	TUBELINE

*** INDICATES THE FLAILS THAT ARE USUALLY IN STOCK**

Most Flails can be ordered with the following suffixes: **H** = Hard Faced • **D** = Tuff Koat

STRAIGHT HANG STEEL FLAIL

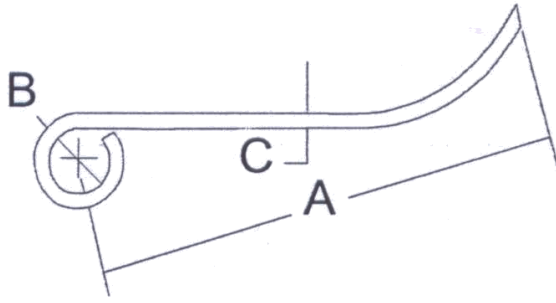

195191

PART #	LENGTH (A)	EYE (B)	MATERIAL (C)	WEIGHT (LBS.)	OEM & PART # (REF. ONLY)
195373*	5"	1"	5/16"	1.55	UNITED PB5430
195702 (250 Pc. Min)	5-1/2"	1.03"	7/16"	2.21	VERMEER #510517232 (Rev. Eye)
195702.500 (250 Pc. Min)	5-1/2"	1.03"	1/2"	3.12	VERMEER #510517232 (Rev. Eye)
195001 (250 Pc. Min)	5-3/4"	1-5/16"	1/2"	3.35	RENN MILL/JIFFY
195063	6"	1-1/4"	5/16"	1.82	
195300	6"	1-5/16"	5/16"	1.85	ACE BT-GSO195300
195765 (250 Pc. Min)	6-1/2"	1-1/32"	7/16"	2.55	VERMEER #E5377H (Rev. Eye)
195048*	6-1/2"	1"	5/16"	1.68	UNITED PB5241
195393	7"	1-5/16"	1/4"	1.61	
195191*	8"	13/16"	5/16"	1.9	ARTSWAY 392028
195371*	8"	1"	5/16"	2.12	UNITED PB2005
195392*	8"	1-1/16"	5/16"	2.13	ARTSWAY 411150
195304	8"	1-1/4"	5/16"	2.25	
195301	8"	1-5/16"	5/16"	2.25	ACE BT-GSO195301
195036*	9-1/2"	1"	5/16"	2.45	UNITED PB5242
195003 (250 Pc. Min)	11"	1"	5/16"	2.76	HILBY/NEWHOUSE
195302	11"	1-5/16"	5/16"	2.85	ACE BT-GSO195302

* INDICATES THE FLAILS THAT ARE USUALLY IN STOCK

Most Flails can be ordered with the following suffixes: **H** = Hard Faced • **D** = Tuff Koat

TWISTED FLAILS

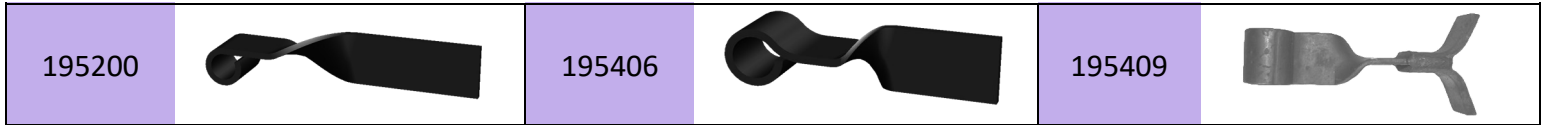

PART #	LENGTH (A)	EYE (B)	MATERIAL (C)	WEIGHT (LBS.)	OEM & PART # (REF. ONLY)
195002 (250 Pc. Min)	5.758"	1-1/4"	1/2"	2.20	
195406	7"	1"	1/4"	1.38	DOUBLE L
195200*	10"	1-1/16"	1/4"	2.01	LOCKWOOD
195405	10-1/2"	1"	1/4"	2.15	DOUBLE L

COMPOST FLAILS

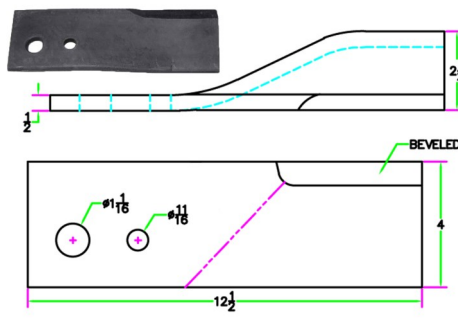
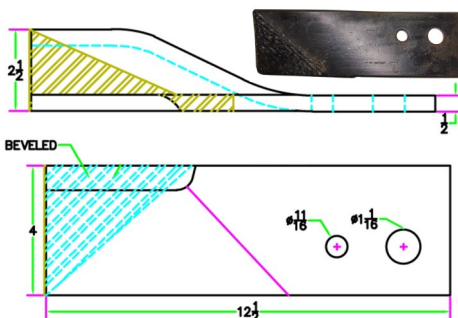
195600LP & 195600LH	WILDCAT	195600RP & 195600RH	WILDCAT
<p>Description: Compost Mixer Blade. Plain/H.F.</p> <p>Length: 12-1/2" Width: 4" Material: 1/4" Hole Size(s):</p> <ul style="list-style-type: none"> (1) 1-1/16" & (1) 11/16" <p>Weight: P=6.67 Lbs. H=6.98 Lbs.</p> <p style="text-align: center;"><i>Left Hand</i></p>		<p>Description: Compost Mixer Blade. Plain/H.F.</p> <p>Length: 12-1/2" Width: 4" Material: 1/4" Hole Size(s):</p> <ul style="list-style-type: none"> (1) 1-1/16" & (1) 11/16" <p>Weight: P=6.67 Lbs. H=6.98 Lbs.</p> <p style="text-align: center;"><i>Right Hand</i></p>	
195605P		K & W	

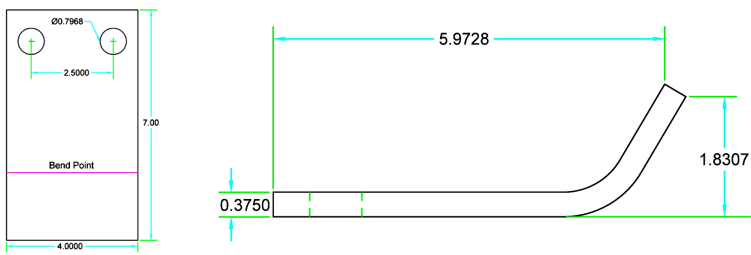
<p>Description: Compost Mixer Blade. Plain</p> <p>Length: 7" Width: 4" Material: 3/8" Hole Size(s):</p> <ul style="list-style-type: none"> (2) 51/64" for 20mm Bolts <p>Weight: 3.10 Lbs.</p> <p style="text-align: center;"><i>Left & Right Hand</i></p>	
--	--

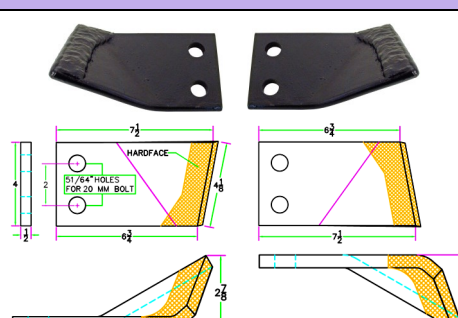
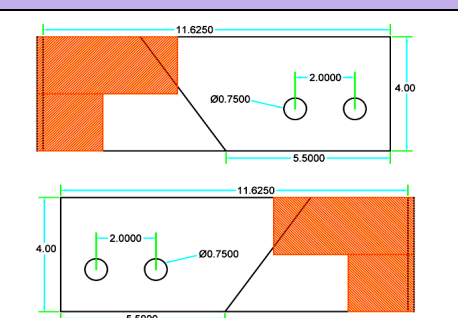
195605LH & 195605RH	K & W	195634LH & 195634RH	WILDCAT
<p>Description: Compost Mixer Blade. Hardfaced</p> <p>Length: 7-1/2" Width: 4" Material: 1/2" Hole Size(s):</p> <ul style="list-style-type: none"> (2) 51/64" for 20mm Bolts <p>Weight: 4.40 Lbs.</p> <p style="text-align: center;"><i>Left & Right Hand</i></p>		<p>Description: Compost Mixer Blade. Hardfaced</p> <p>Length: 11-5/8" Width: 4" Material: 3/4" Hole Size(s):</p> <ul style="list-style-type: none"> (2) 3/4" Bolt Holes <p>Weight: 10.25 Lbs.</p> <p style="text-align: center;"><i>Left & Right Hand</i></p>	





ONION KNIVES

F410550	FALC	F430513	FALC
<p>Description: Straight cut onion knife. Plain</p> <p>Length: 5-7/8" Width: 3-1/2" Material: 5/16"/8mm Hole Size: 23/40"</p> <p>Part # F410550D for Hard Faced</p>		<p>Description: Straight cut onion knife. Plain</p> <p>Length: 3-3/8" Width: 3-1/2" Material: 5/16"/8mm Hole Size: 23/40"</p> <p>Part # F430513D for Hard Faced</p>	
F430786	FALC	F430787	FALC
<p>Description: Slant cut onion knife. Plain</p> <p>Length: 6-19/64" Width: 3-1/2" Material: 5/16"/8mm Hole Size: 23/40"</p> <p><i>Left Hand</i></p> <p>Part # F430786D for Hard Faced</p>		<p>Description: Slant cut onion knife. Plain</p> <p>Length: 6" Width: 3-1/2" Material: 5/16"/8mm Hole Size: 23/40"</p> <p><i>Right Hand</i></p> <p>Part # F430787D for Hard Faced</p>	

ONION TILLER BLADES

TV-8.5LP	FERGUSON	TV-8.5RP	FERGUSON
<p>Description: Straight cut onion knife. Plain.</p> <p>Length: 8-1/2" Width: 1-1/4" Material: 10mm thick Hole Size: 15/32"</p> <p><i>Left Hand</i></p>		<p>Description: Straight cut onion knife. Plain.</p> <p>Length: 8-1/2" Width: 1-1/4" Material: 10mm thick Hole Size: 15/32"</p> <p><i>Right Hand</i></p>	
TV-8.5HFL	FERGUSON	TV-8.5HFR	FERGUSON
<p>Description: Straight cut onion knife. Hard Faced.</p> <p>Length: 8-1/2" Width: 1-1/4" Material: 10mm thick Hole Size: 15/32"</p> <p><i>Left Hand</i></p>		<p>Description: Straight cut onion knife. Hard Faced.</p> <p>Length: 8-1/2" Width: 1-1/4" Material: 10mm thick Hole Size: 15/32"</p> <p><i>Right Hand</i></p>	

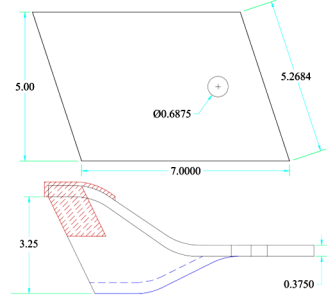
PASTURE GROOVING BLADES

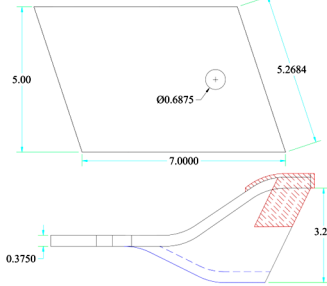
XPGLH		XPGLP		XPGLH & XPGLP DIMENSIONS
<p>Description: Pasture Grooving Blade. Hard Faced.</p> <p>Length: 7" Width: 5" Material: 3/8" thick Hole Size: 11/16"</p> <p><i>Left Hand</i></p>		<p>Description: Pasture Grooving Blade. Plain.</p> <p>Length: 7" Width: 5" Material: 3/8" thick Hole Size: 11/16"</p> <p><i>Left Hand</i></p>		 <p>Dimensions: 5.00, 7.0000, 5.2684, Ø0.6875, 3.25, 0.3750</p>
XPGRH		XPGRP		XPGRH & XPGRP DIMENSIONS
<p>Description: Pasture Grooving Blade. Hard Faced.</p> <p>Length: 7" Width: 5" Material: 3/8" thick Hole Size: 11/16"</p> <p><i>Right Hand</i></p>		<p>Description: Pasture Grooving Blade. Plain.</p> <p>Length: 7" Width: 5" Material: 3/8" thick Hole Size: 11/16"</p> <p><i>Right Hand</i></p>		 <p>Dimensions: 5.00, 7.0000, 5.2684, Ø0.6875, 3.25, 0.3750</p>

FEED WAGON REPLACEMENT BLADES

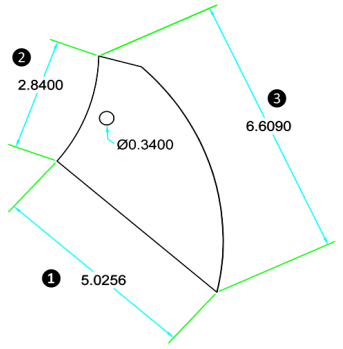
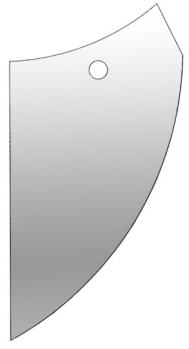
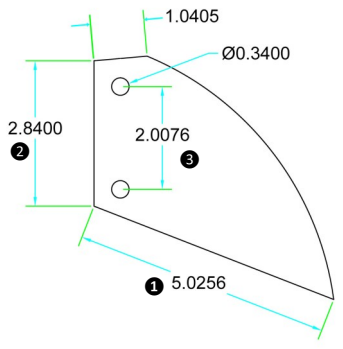
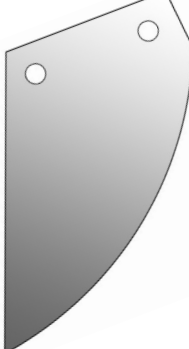
XPKIRBY	for KIRBY Feed Wagons	
<p>Description: Replacement Blade.</p> <p>(approximations)</p> <p>① Length: 5-1/4" ② Width: 2-27/32" ③ Height: 6-19/32"</p> <p>Material: 3.5mm Hole Size: 11/32"</p>		
XPWATTS	for WATTS Feed Wagons	
<p>Description: Replacement Blade.</p> <p>(approximations)</p> <p>① Length: 5-1/4" ② Width: 2-27/32" ③ Hole Centers: 2-1/64"</p> <p>Material: 3.5mm Hole Size: 11/32"</p>		

ALL **NORWEST STEEL FLAILS** ARE FULLY HEAT TREATED FOR EXTRA STRENGTH & LONG WEAR. ALL FLAILS ARE MANUFACTURED WITH 2" WIDE MATERIAL.

MINIMUM ORDER is 250 for OBSOLETE and LOW VOLUME parts.

CUSTOM KNIVES CAN BE MADE IF NEEDED. OTHER FLAIL SIZES AVAILABLE UPON REQUEST. PLEASE CALL NORWEST FOR A QUOTE.

FLAIL KNIVES

*Knives may be ordered with the following suffixes: P = Plain, H = Hard Faced, D = Tuff-Koat

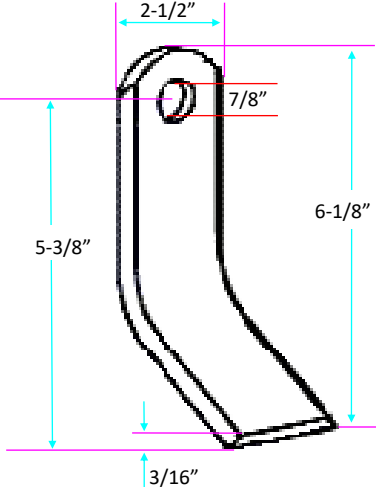
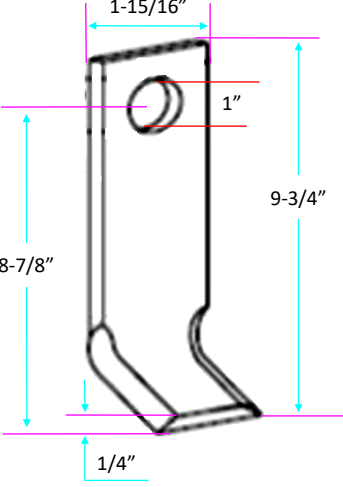
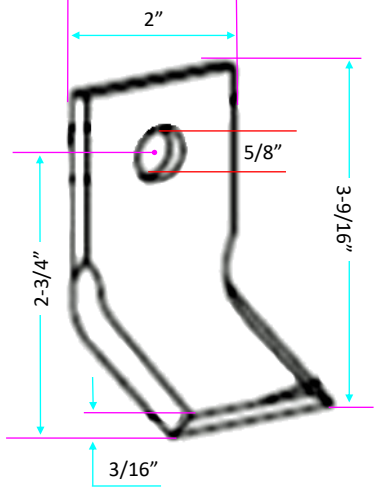
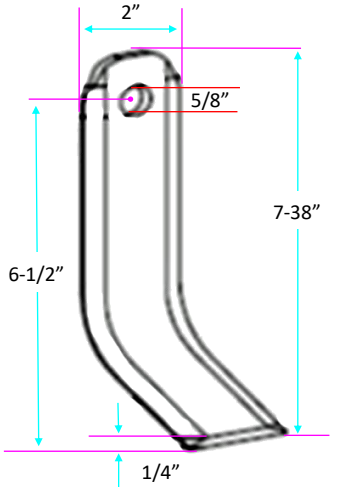
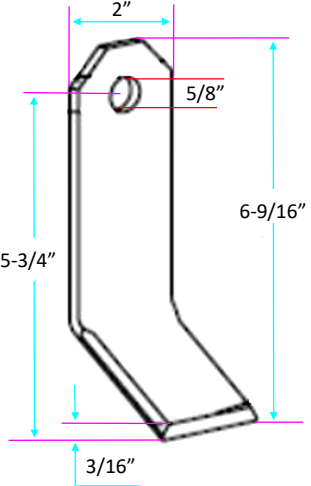
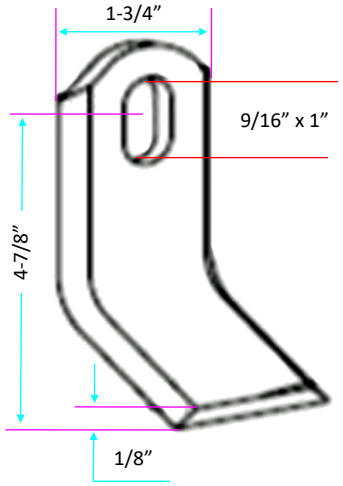
6021-606P		DANDL	6021-899P		IHC
<p>UTILIZED FOR: DANDL (R2560)</p> <p>MOUNTS WITH: 6023-706 (1/2") D-RING DANDL (SA2021) 6023-711 (1-1/4") OVAL RING DANDL (SA2016-1HD) 6024-722 U-BAR DANDL (SA2016-1HD) 6023-707 D-RING (REARS ONLY)</p>		<p>UTILIZED FOR: INTERNATIONAL HARVESTER (491096R1)</p>			
6021-901P		DANDL	6021-636P		ALLOWAY
<p>UTILIZED FOR: DANDL (SA2027) VRISIMO (CD2100) REARS (FL960)</p> <p>MOUNTS WITH: 6023-706 (1/2") D-RING DANDL (S2021) 6023-711 (1-1/4") OVAL RING DANDL (S2047) 6024-742 U-BAR (REARS ONLY) 6023-707 D-RING (REARS ONLY)</p>		<p>UTILIZED FOR: ALLOWAY (505-3-0001)</p> <p>MOUNTS WITH: 6023-708 D-RING 6023-743 U-BAR ALLOWAY (505-3-0014)</p>			
6021-914P		DANDL	6021-936P		FULL CUT TIGER
<p>UTILIZED FOR: DANDL (SA2039)</p> <p>MOUNTS WITH: 6023-706 D-RING DANDL (S2021) 6023-722 U-BAR DANDL (SA2016-HD) VRISIMO (MIGHTY MAX) CD2200</p>		<p>UTILIZED FOR: TIGER (TF1019)</p> <p>MOUNTS WITH: CLEVIS (TF1020) NUT & BOLT (TF10213)</p>			

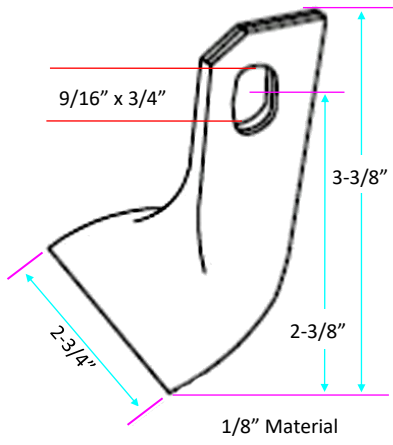
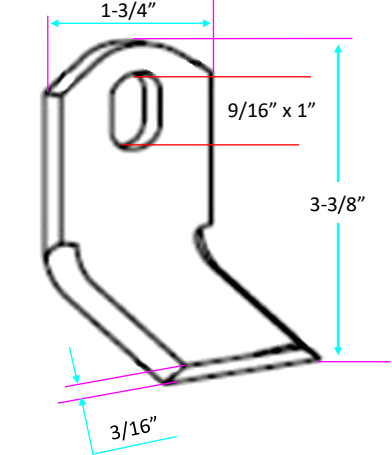
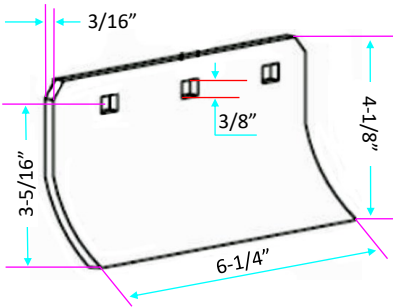
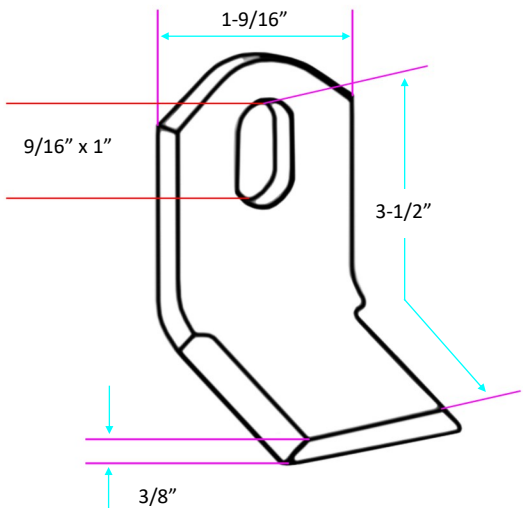
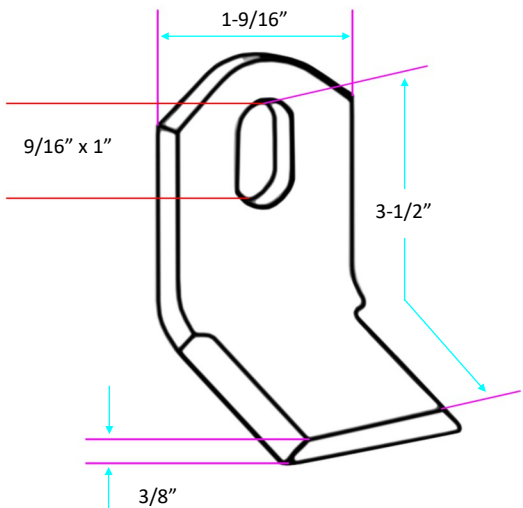
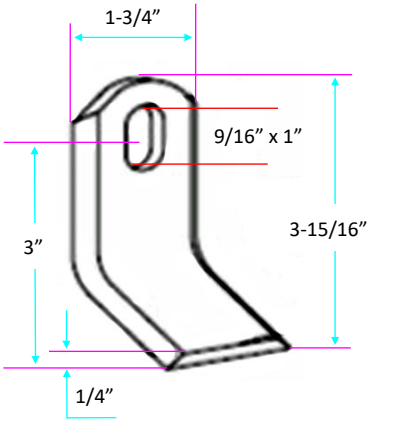
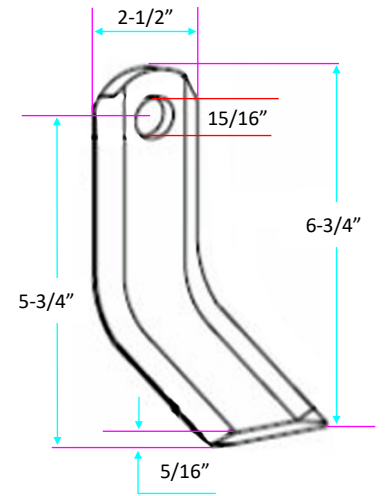

FLAIL KNIVES

*Knives may be ordered with the following suffixes: P = Plain, H = Hard Faced, D = Tuff-Koat

6021-709P	DANDL	6021-996P	STD. MOTT
<p>CUP KNIFE</p> <p>UTILIZED FOR: DANDL (2042) DEERE (E31900) FLORY VRISIMO (CD2135) MIGHTY MAX</p> <p>MOUNTS WITH: 6023-709 (7/16") D-RING Dandl(2017), JD(E31903), Flory(MR6002), Vrisimo(CD2135) 6023-706 (1/2") D-RING Dandl(SA2021) 6023-711 (1-1/4") OVAL RING Dandl(SA2047), Vrisimo(CD2120) 6023-711 (1-1/2") OVAL RING Dandl(SA2111), Flory(MR6001)</p>		<p>UTILIZED FOR: DANDL (IA2016) MOTT (100759)</p> <p>MOUNTS WITH: 6023-717 (SHACKLE & PIN) OR 6023-020 (BOLT & NUT)</p>	
6022-735P	MATHEWS	6021-707P	HEAVY MOTT
<p>UTILIZED FOR: MATHEWS (15208) SERVIS-RHINO</p> <p>MOUNTS WITH: CARRIAGE BOLT & NUT</p>			
6021-007P	FULL CUT EDWARDS	6021-006P	LOFTNESS
<p>UTILIZED FOR: EDWARDS (HMB217-IF)</p>		<p>*FORMERLY 6021-601P</p> <p>UTILIZED FOR: LOFTNESS (8136, 8028 - 90°) LOFTNESS (5986 - OLD STYLE) VRISIMO (CD2185) REARS (FL 8021) LOFTNESS (8020 - NEW STYLE)</p> <p>MOUNTS WITH: 6024-602 SLOTTED BAR VRISIMO (CD 2165) VRISIMO(CD2175) BUSHING</p>	

FLAIL KNIVES

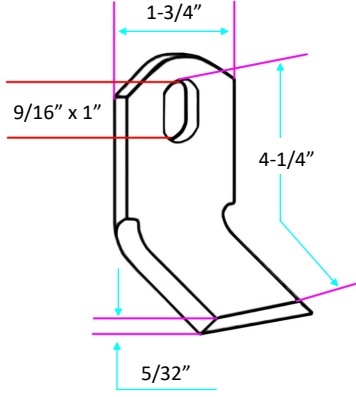
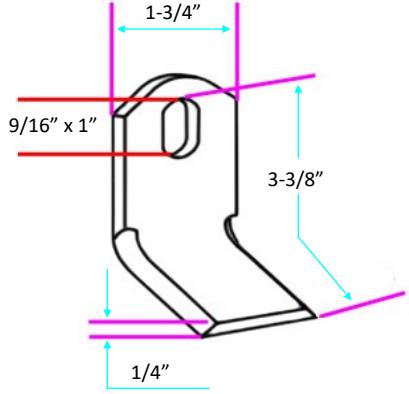
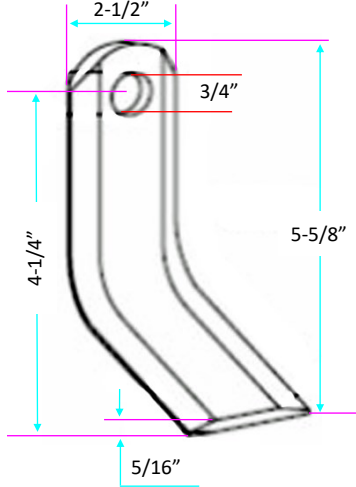
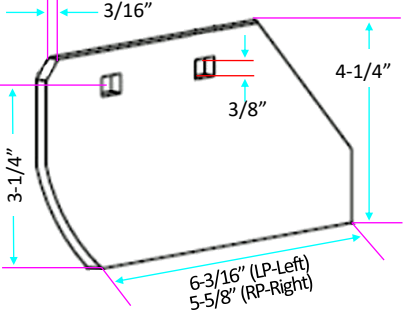
*Knives may be ordered with the following suffixes: P = Plain, H = Hard Faced, D = Tuff-Koat

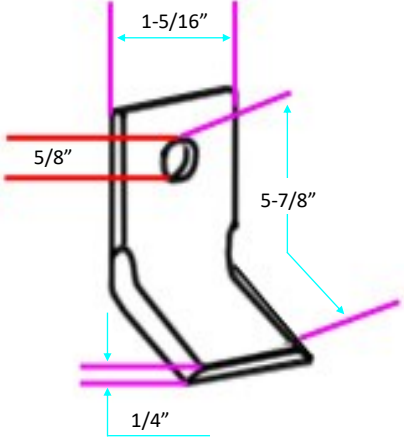
6021-843P LIGHT DUTY EDWARDS		6021-982P EDWARDS	
<p>UTILIZED FOR: EDWARDS (HMB-217)</p>		<p>UTILIZED FOR: EDWARDS (HMB-217-1)</p>	
6021-876P DEERE		6022-735LP & RP MATHEWS	
<p>*FORMERLY 6021-875P UTILIZED FOR: DEERE (P60322, P58586, & E48308) BALZAR (24153) BRENT (9001192) LOFTNESS (S330050V) UFT (50800037) MIGHTY MAX</p> <p>MOUNTS WITH: 6023-704 D-RING DEERE (E48307) LOFTNESS (S330070V) 6024-737 U-BAR DEERE (E48305)</p>		<p>UTILIZED FOR: MATHEWS (0015211 L/H) MATHEWS (0015212 R/H) RHINO SERVIS</p> <p>MOUNTS WITH: CARRIAGE BOLT & NUT</p>	
6021-604P FOX BRADY		 <p>NORWEST MANUFACTURING</p> <p>Phone: (208)436-1770 • Fax: (208)436-1776</p>	
<p>UTILIZED FOR: FOX BRADY (65143) BLAZER (12357) BUFFALO (11040039) SHULTZ-MASSEY (180) OLD CASE, HINIKER (000-65143)</p> <p>MOUNTS WITH: 6023-708 D-RING FOX BRADY (65142), BALZAR (12356), Buffalo (18020019) 6024-710 U-BAR FOX BRADY (65141), BALZAR (12355), Buffalo (02070278) 6023-699 U-BAR FOX BRADY (1904 Old Style)</p>			

FLAIL KNIFE MOUNTING HARDWARE

D-RINGS, BUSHINGS, & U-BARS

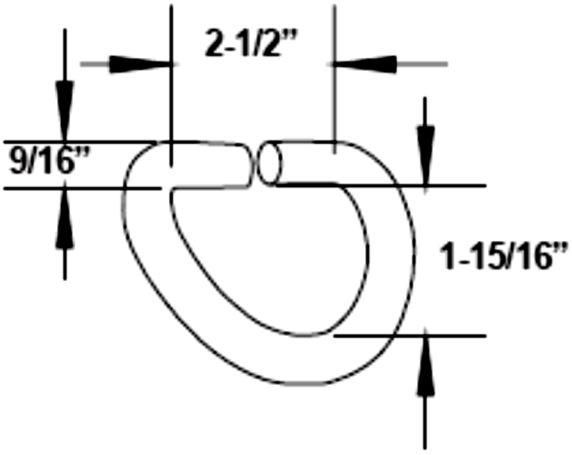
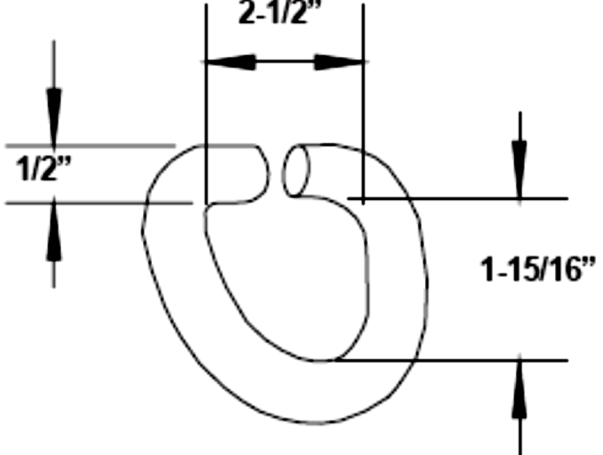
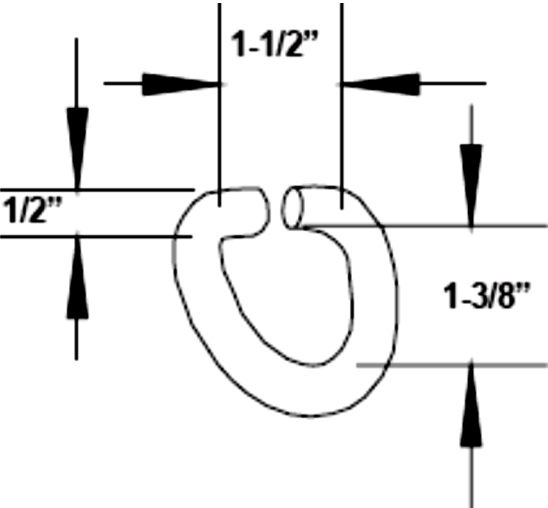
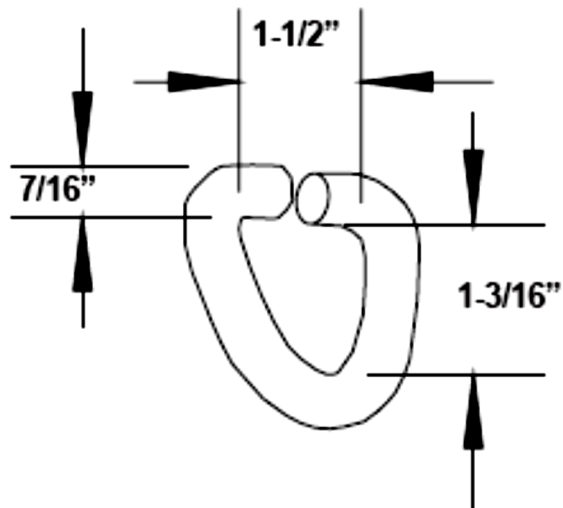
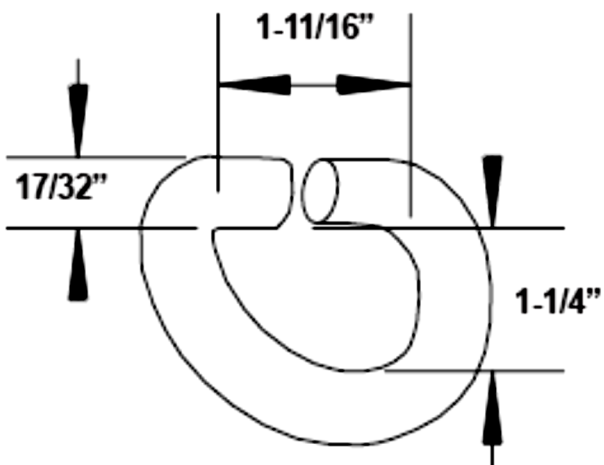
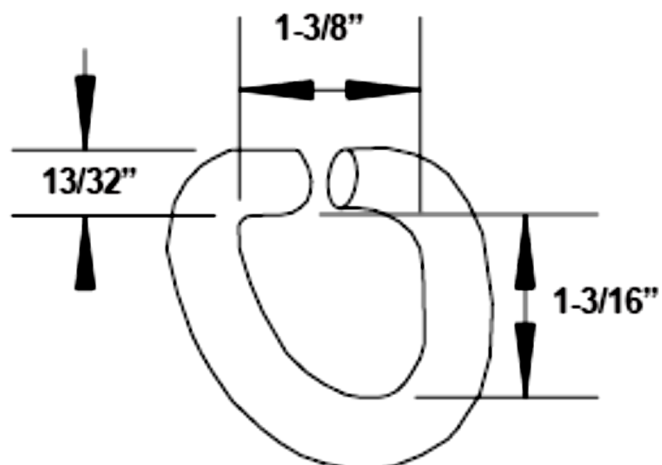
6023-704	D-RING	6023-705	D-RING
			
6023-706	D-RING	6023-707	D-RING
			
6023-708	D-RING	6023-709	D-RING
			

FLAIL KNIFE MOUNTING HARDWARE

D-RINGS, BUSHINGS, & U-BARS

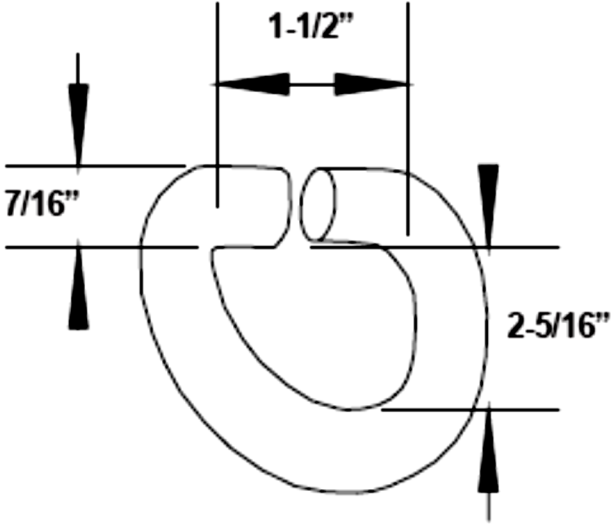
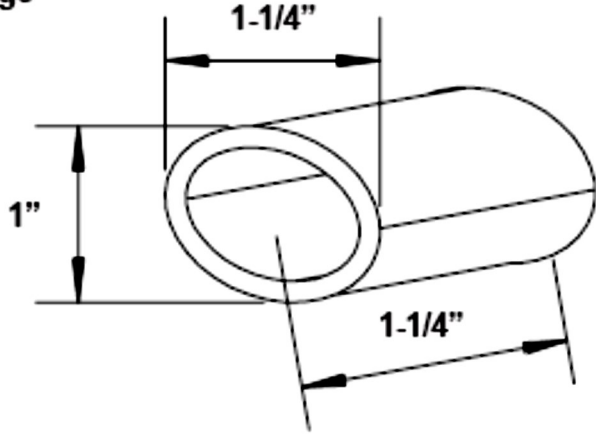
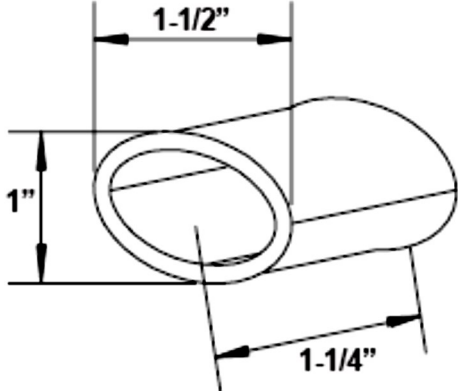
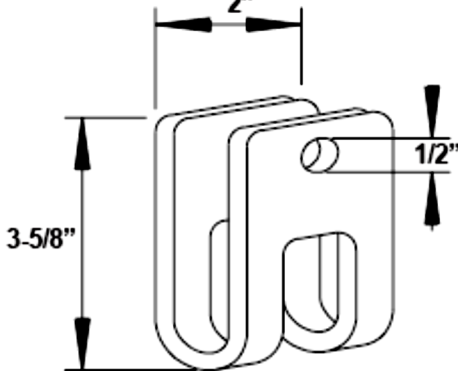
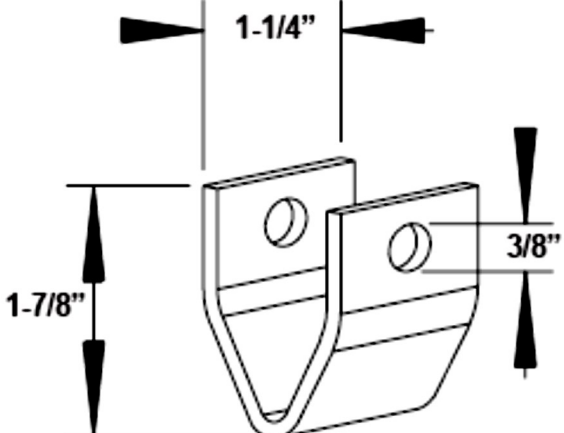
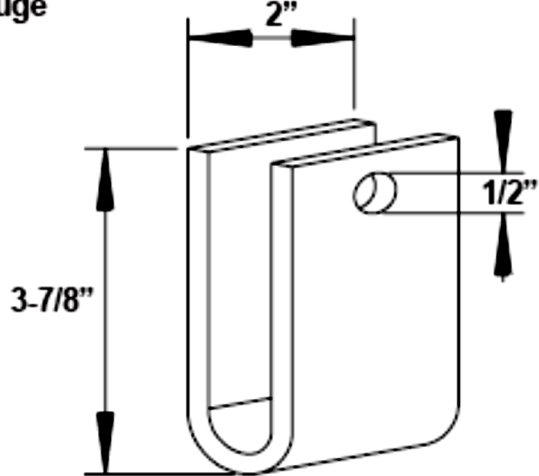
6023-710	D-RING	6023-711 (1-1/4")	OVAL RING HANGER
		<p>.12 gauge</p> 	
6023-712 (1-1/2")	OVAL RING HANGER	6024-602	U-BAR
<p>.12 gauge</p> 		<p>.25 gauge</p> 	
6024-628	U-BAR	6024-702	U-BAR
<p>.125 gauge</p> 		<p>.25 gauge</p> 	

FLAIL KNIFE MOUNTING HARDWARE

D-RINGS, BUSHINGS, & U-BARS

6024-704

U-BAR

.25 gauge

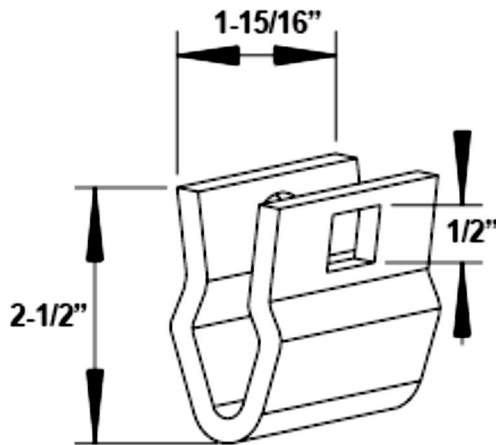

6024-722

U-BAR

.16 gauge

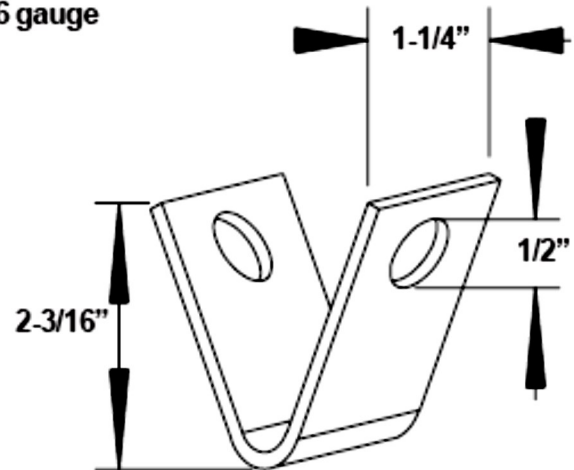

6024-737

U-BAR

.25 gauge

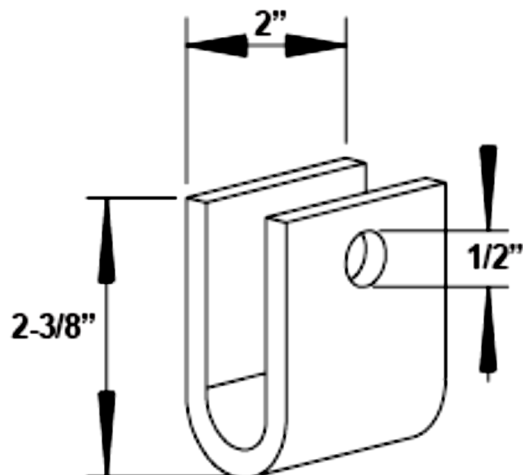

6024-742

U-BAR

.25 gauge

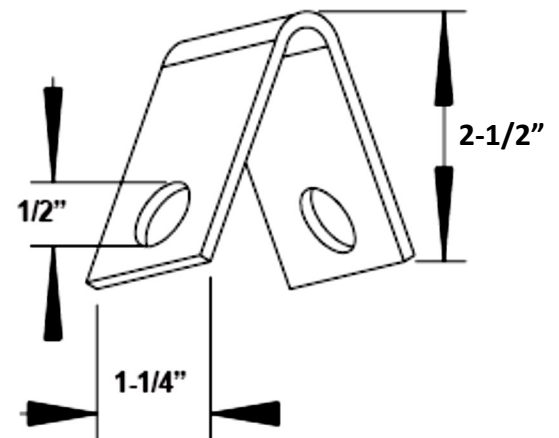

6024-743

U-BAR

.25 gauge

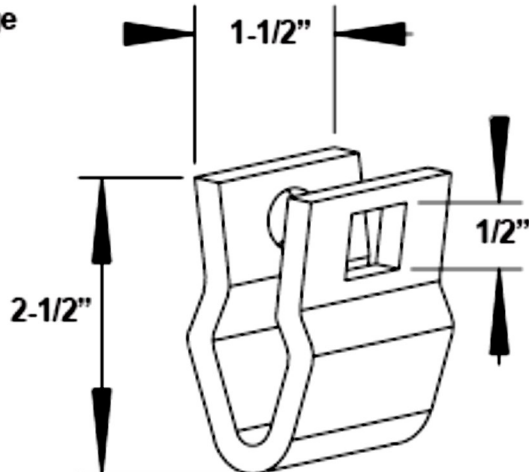

F.Y.I.

Not all items in stock. Please Call Norwest for Pricing and Availability.

Measurements are Approximate and for Reference purposes.

(208)436-1770